

Prenox 25/22
Doble avance

Talla R-S

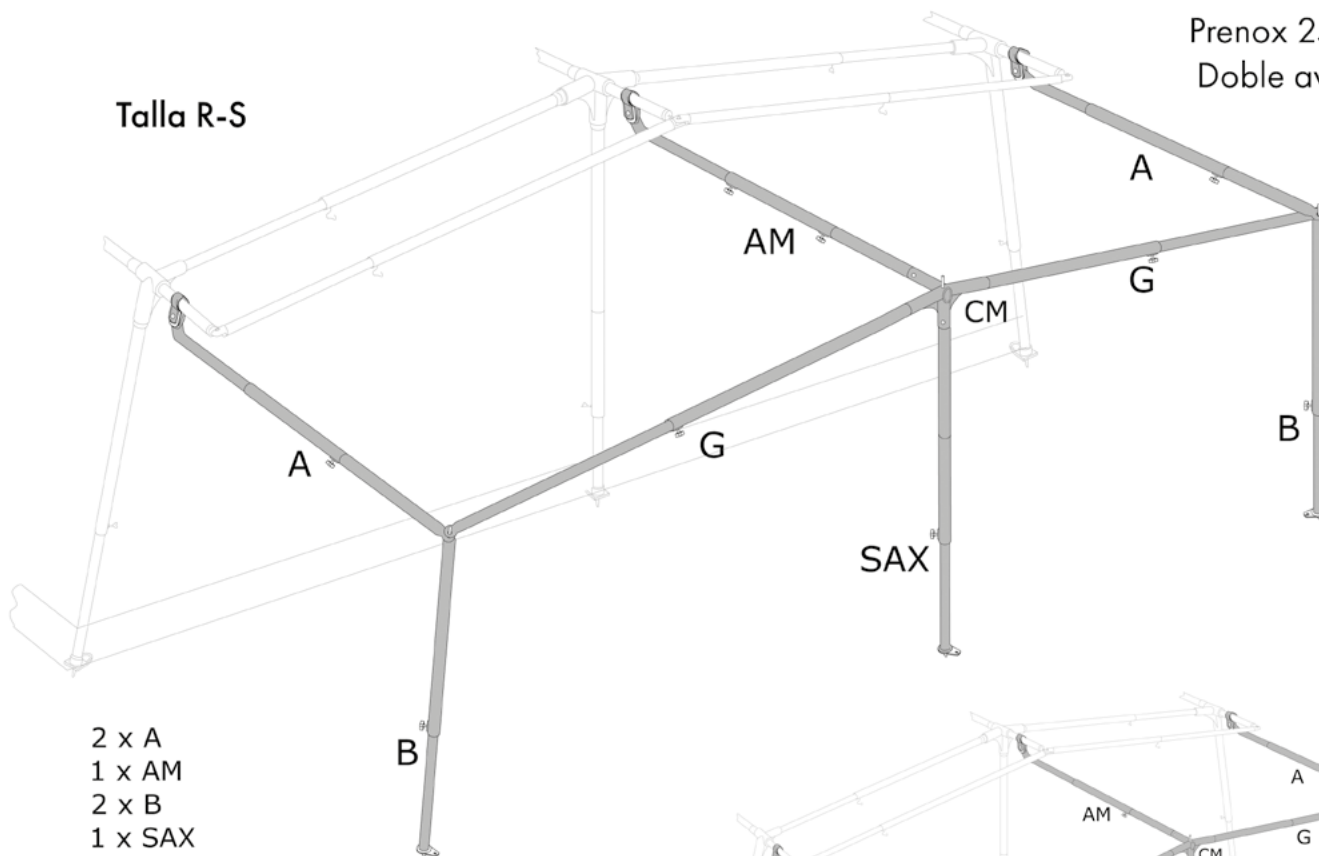

- 2 x A
- 1 x AM
- 2 x B
- 1 x SAX
- 1 x CM
- 2 x G

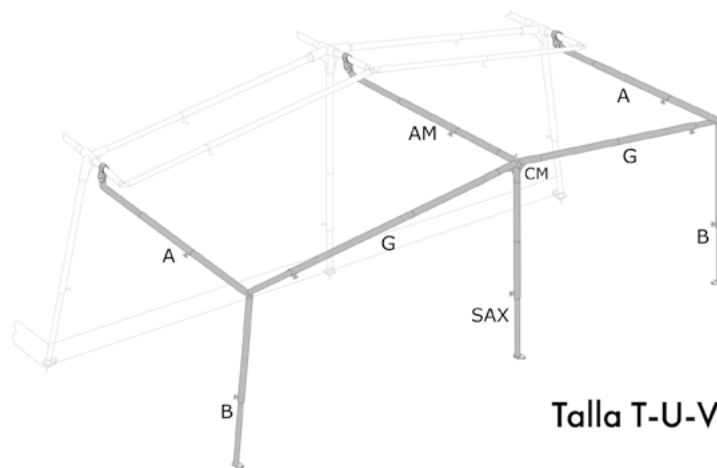

Talla T-U-V

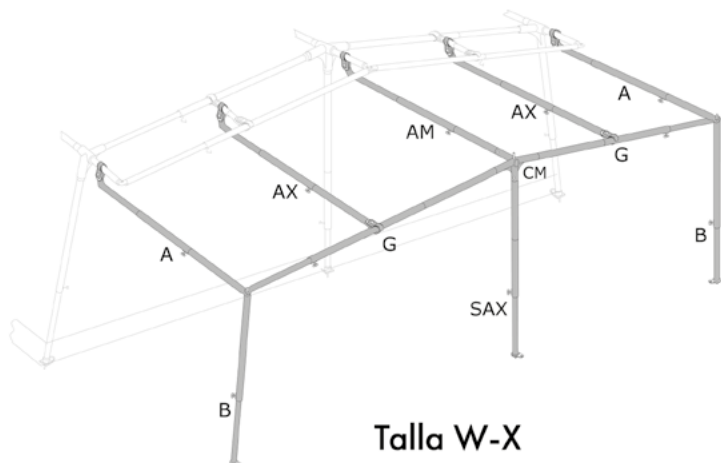

Talla W-X

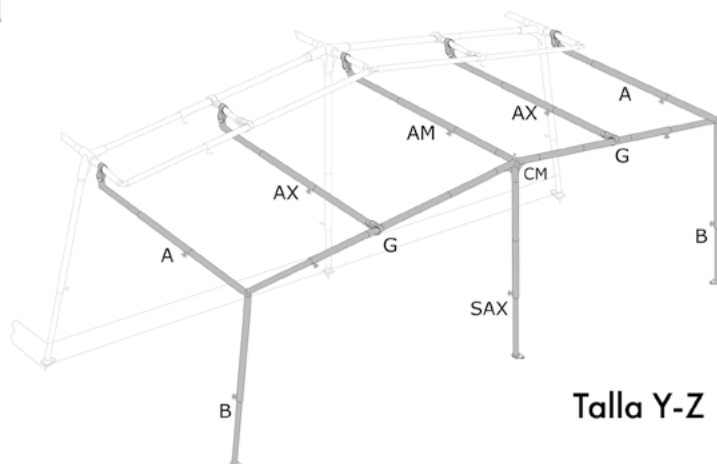

Talla Y-Z

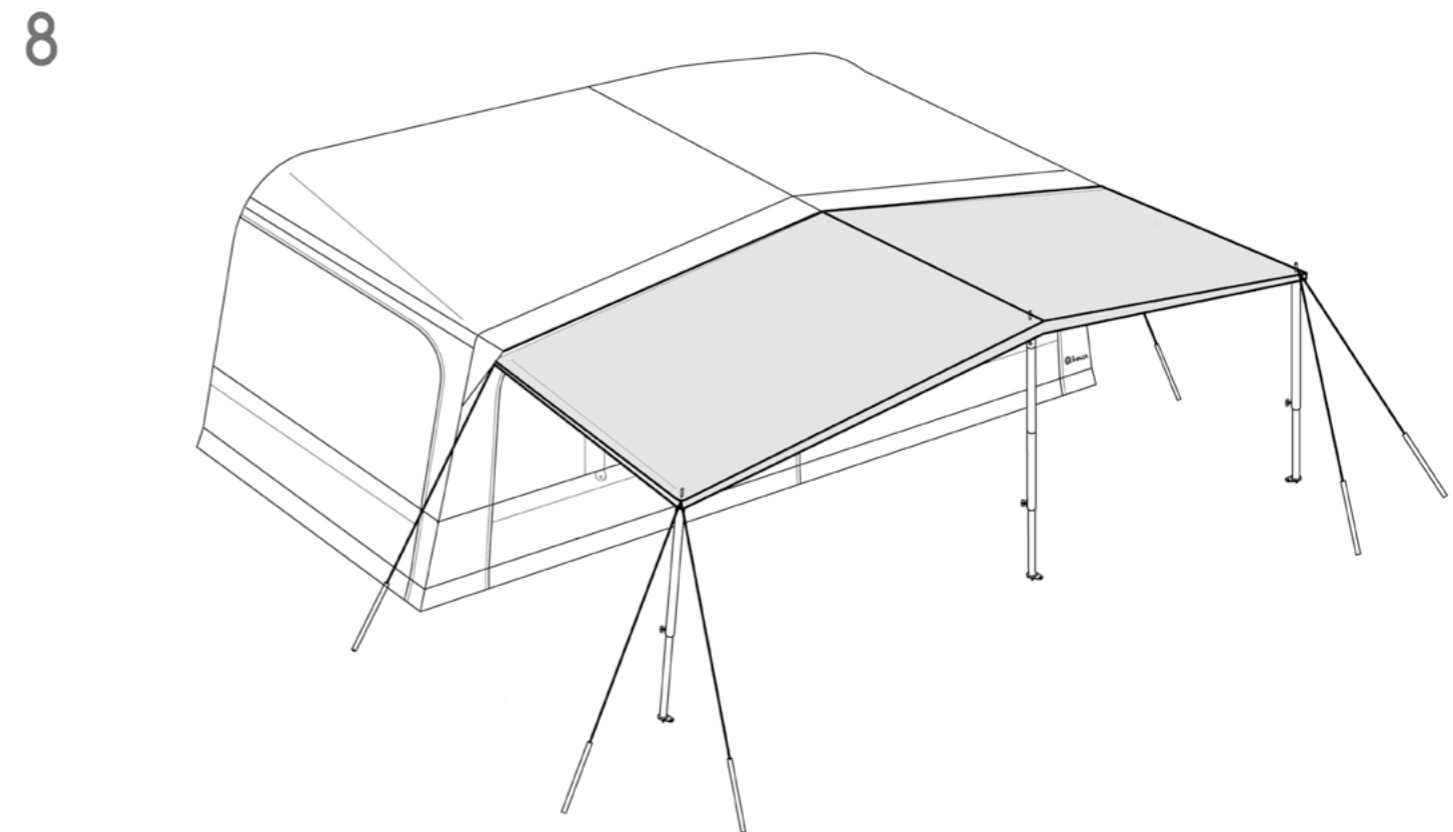
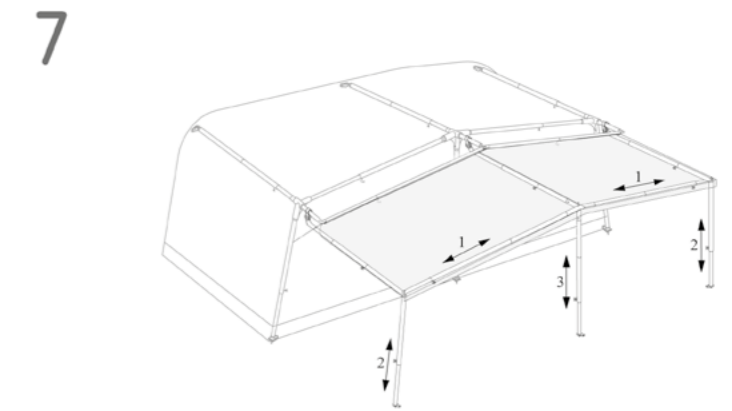
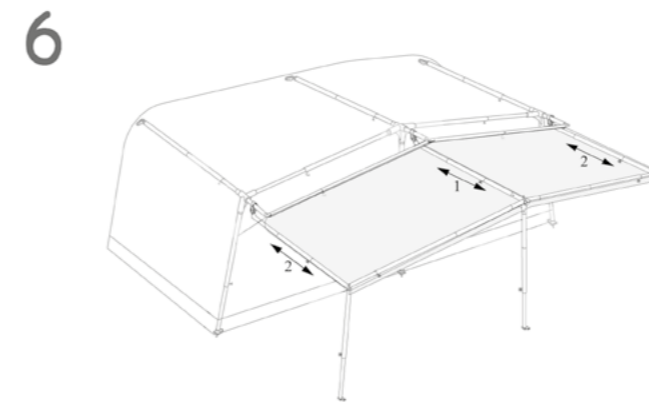
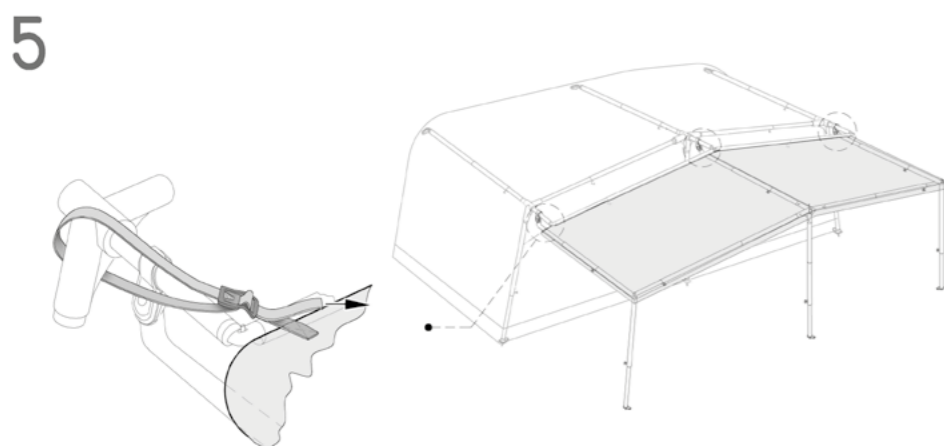
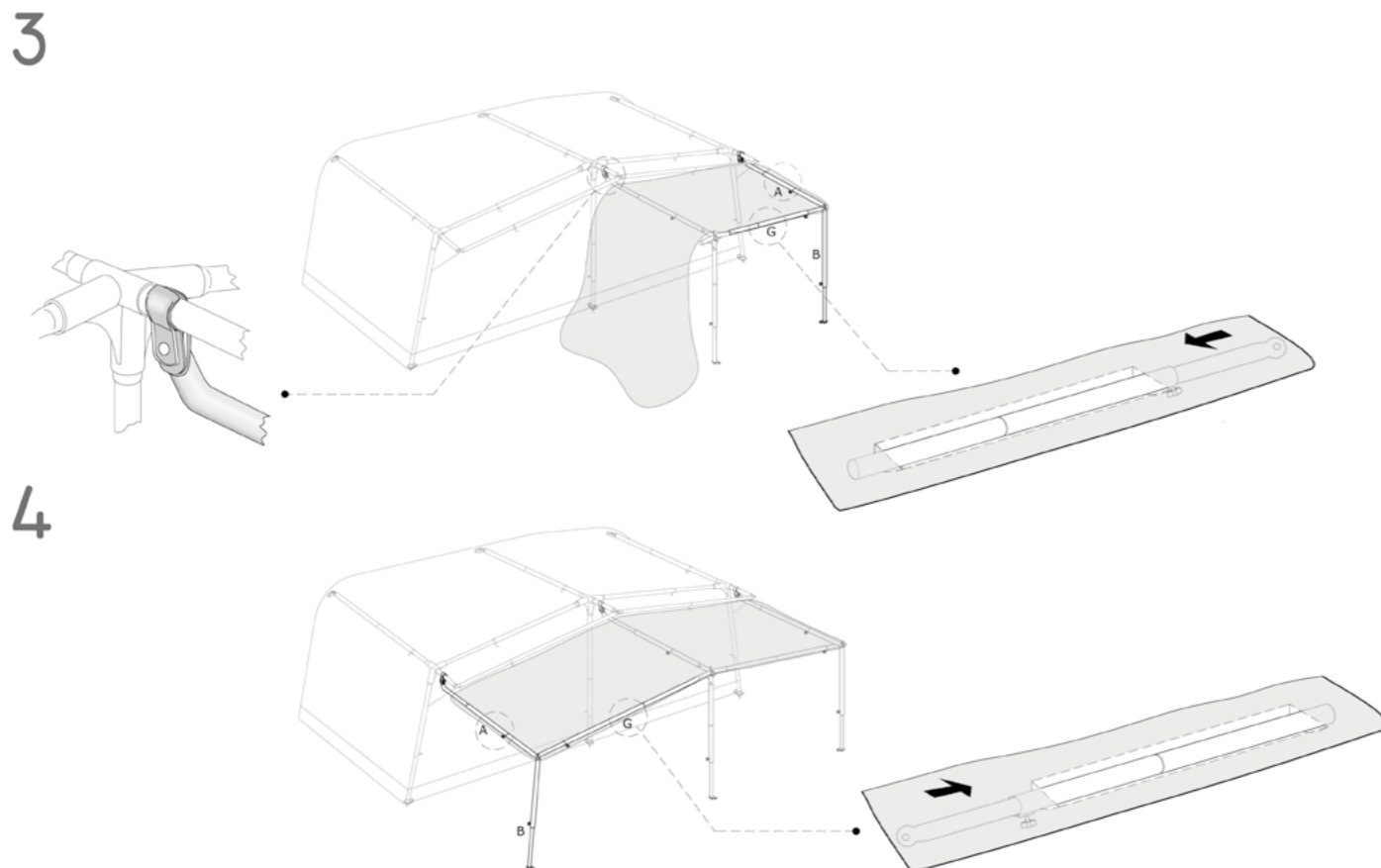
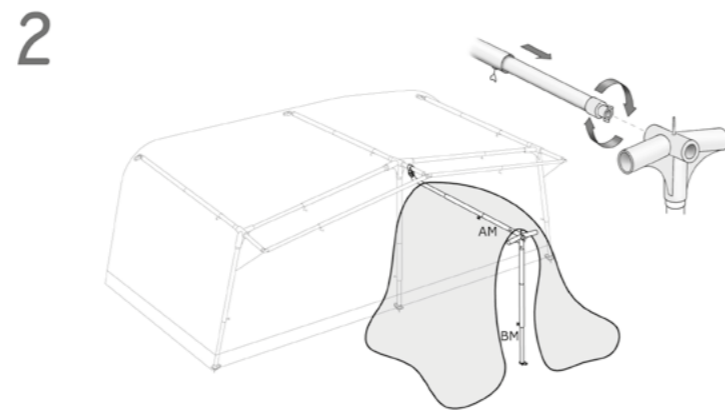
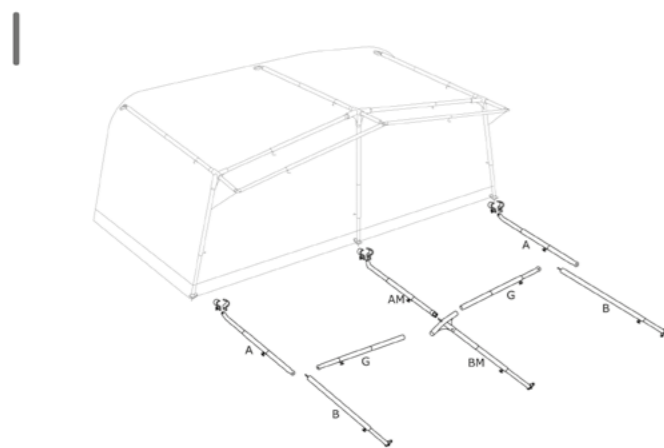

ESPAÑOL

1. Distribuir la estructura en el suelo sobre una lona protectora frente a su avance. **2.** Montar la estructura por la parte central. Primero el tubo del techo abrazando el tubo visera, la cruzeta y la pata después. Desplegar la lona. Colocarla cuidadosamente sobre el tubo central. **3.** Seguir por uno de los lados. Primero el tubo enlace centro-lado, después la pata con cruzeta, y después el tubo lateral del techo. Asegúrese de colocar los tubos a través de las vainas de la lona. **4.** Misma operación al otro lado. **5.** Atar los extremos de la lona a los codos y cruzeta del avance mediante las cintas con hebilla. **6.** Tensar los tubos, primero el central del techo, luego los tubos laterales. **7.** Subir las patas y dar tensión a los tubos frontales. **8.** Clavar las patas y dar tensión mediante los vientos tensores.

ENGLISH

1. Lay out the components of the frame over a protective sheet. **2.** Take the central roof pole, then push the eyelet in the sun canopy roof onto the spiked central leg. Lock the roof and leg poles together. Extend the roof pole for stability (set the leg at a height you can reach easily). **3.** Take the front pole and connect the centre to the side joint. Then repeat the previous point with the roof and leg poles to assemble one side. **4.** Repeat process on other side to finish frame on main body of sun canopy. **5.** Tie the canvas to the sun canopy frame. **6.** Apply tension to the central roof pole. Next, tension the front poles, then the remaining roof poles. **7.** Extend the leg poles. Peg the outer legs and central leg. **8.** Finally, attach and tension guy ropes for extra stability, thus completing the assembly of your front sun canopy.

Doble avance

LATERAL OPCIONAL

